



NITROUS OXIDE CONTROLLER INSTALLATION & OPERATION MANUAL

INDEX

Installation Instructions.....	pg 1	General Info / Definitions.....	pg 4
Button Use & Programming.....	pg 2	Wiring for Nitrous & Ignition Retard.....	pg 5
Pro-Full Feature.....	pg 2	Wiring with MRC-1 Relay Center.....	pg 6
Setting Nitrous Timers.....	pg 2&3	RPM Switch & Remote Display Wiring.	pg 7
RPM Switch & Optional Timer.....	pg 3&4	Settings & Parameters.....	pg 8

INSTALLATION

Using #8 screws through the rubber grommets in the base, mount the Nitrous Controller away from heat, vibration and the ignition system.

Make sure the driver can reach the buttons when strapped in and angle the unit if needed so the display can be read straight on. If the box is mounted so the display is viewed more than 10 degrees off center, it will be hard to read.

Wire the Nitrous Controller as shown on pages 5-7. Make sure the power lead comes straight from the master switch and the ground goes to a solid chassis ground, not sheet metal panels.

BUTTON QUICK REFERENCE

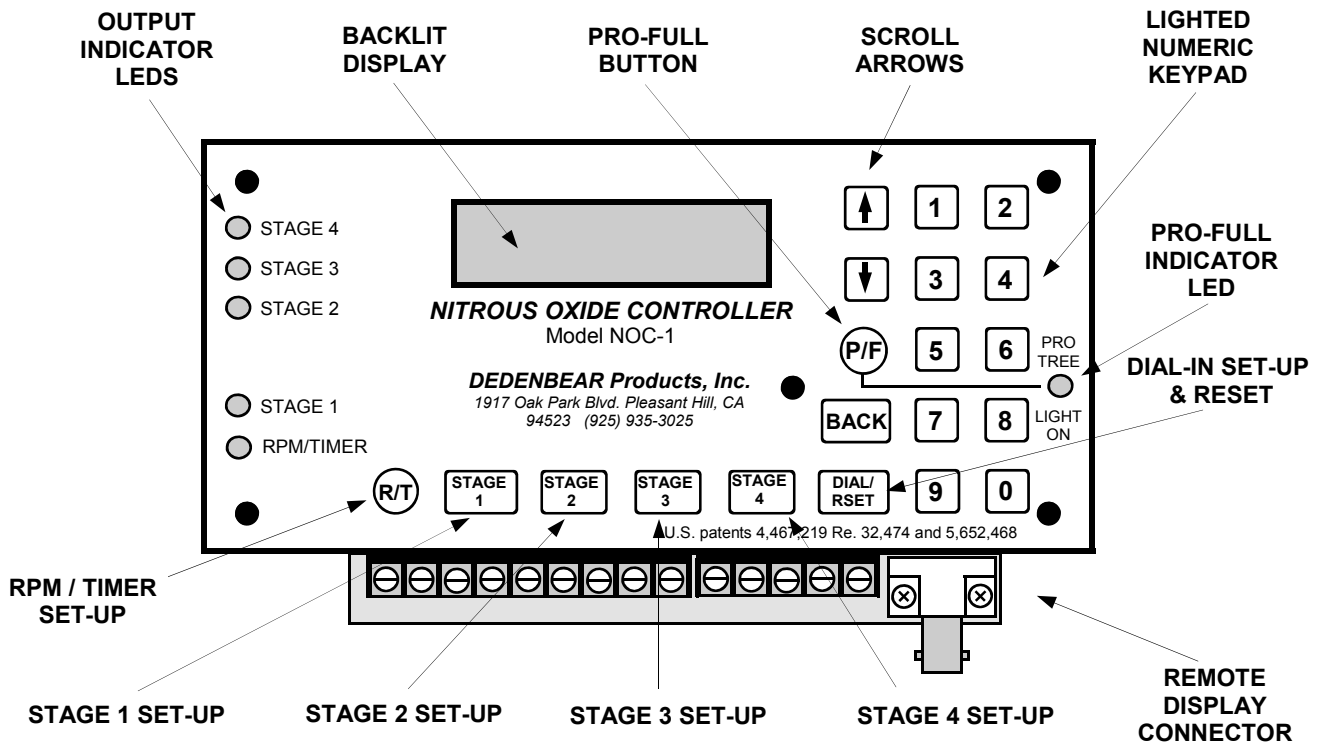

PROGRAMMING BUTTONS



STAGE Buttons: These buttons access your 4 independent stage settings (numbered accordingly). Each time you press a stage button, different set-up screens come up and allow you to make changes to your timer settings (Start time & Stop time).



RPM/TIMER (R/T) Button: This button accesses your RPM Activated Switch **OR** 4 stage timer settings. Each time you press the R/T button, different set-up screens come up and allow you to make changes to your Shift Point(s), Disable Time, Shifter Type, and Number Of Cylinders **OR** switch to TIMER and change your 4 Timer settings (timer T1 through T4).



Dial/Reset Button: When in the run screen, press this button to access your dial-in setting. The dial in setting is only important when using a RD-1 Remote Display unit. When in a set-up screen this button is used for turning stages of nitrous on or off, setting the box for the type of equipment it will be running (Shifter Type, Number of Cylinders, etc.). Press and hold the R button to make the change. This button also can be used to cancel all of the nitrous timers during the pass.



Arrow (scroll) Buttons: These buttons are used for making small changes to your settings. You can add to a setting by pressing the up arrow, or subtract with the down. If you push and hold an arrow key, the setting will continue to change faster and faster.



Number Buttons: These buttons are used for making large changes to your settings . Simply type in the number you want. For example, if you wanted to change an ON time to 5.730, you would press 5730.



BACK Button: This button is used if you accidentally pass the screen you wanted when stepping through the set-up screens . Press the Back button to move back one set-up screen.

PRO-FULL BUTTON



The NOC-1's **PRO-FULL** feature allows you to switch between two complete setting groups. When you switch between classes, just push and hold the PRO-FULL button to switch between groups of settings. The red LED indicator light on the right side of the box will indicate which setting group you are in. When you are in the **PRO** group, the **PRO-FULL** LED will turn on and stay on. When you are in the **FULL** group, the LED will be off except for momentary flashing while making adjustments, which is normal.

REMEMBER: It is extremely important when you change a setting that you are in the setting group (PRO or FULL) in which you want the change to occur since each group has it's own complete set of settings.

SETTING NITROUS TIMERS, STAGE 1,2, 3 & 4

The NOC-1 has 4 separate stage outputs (a 5th timer is available if the RPM output is not used. See the RPM switch section for details). Each stage controls both a normally open positive output for triggering nitrous relays and a normally closed negative output for controlling a retard simultaneously. For example, when the Stage 1 output powers out to turn on your first stage nitrous relay, Retard 1 output removes ground to activate your first stage of retard. You do not have to use both outputs when using a stage; if you want to time nitrous without running a retard, simply do not wire the Retard output. Vice versa, if you wish to time a retard without nitrous, do not wire the Stage output.

**READY TO RUN
DIAL-IN 9.00**

RUN SCREEN: This is the screen the NOC-1 will display when it is "ready to run". If you are **not** using the remote display dial-in board (part# RD-1) the DIAL-IN setting is **not** important. This setting will **not** effect any other settings or timing in the NOC-1.



To set your timers, press the STAGE 1, STAGE 2, STAGE 3 or STAGE 4 button to enter each of the respective timer menus. Each time you press the button it will advance to the next set-up screen. After advancing through all the screens, or after 8 seconds without making a change, the box returns to run mode. If you happen to go too fast and pass the set-up screen you wished to change, you may use the BACK button to back up.

SETTING NITROUS TIMERS, STAGE 1, 2, 3 & 4 (CONTINUED)

**STAGE STRT 0.500
1 STOP 2.500**

The first screen that will be displayed is a summary screen that shows both of your nitrous timer settings for quick reference. This screen simply lets you take a look at what you have set in both your start and stop timers. No changes to the timers can be made in this screen and like all the other prompt screens, this screen will disappear and return to run mode after 8 seconds.

In this example, notice how the START time is set higher than the STOP time. If you accidentally set your start time higher than the stop timer, the "STAGE 1 IS SET WRONG" error message will appear. Reset the timers in proper sequence to eliminate the error. When the start time and the stop time are set the same as one another, they will cancel each other out and the output will not change.

**SETUP STAGE 1
START TIME 0.500**

The two set-up screens following the summary screen are where you change your start and stop timers. Use the scroll arrows or the number buttons to make changes. Both timers start at the release of the transbrake solenoid so if you had 1.000 in the start timer, and 2.500 in the stop timer, the car would launch with no nitrous for 1 second, the nitrous would turn on for 1.5 seconds (duration = stop time minus start time) and then the nitrous would turn off for the remainder of the pass.

**SETUP STAGE 1
ON or OFF: ON**

The last set-up screen in each stage menu is the ON or OFF screen. Push and hold the Dial/Reset button to turn the stage on or off. When in the OFF position, the stage will not cycle and will not prompt you for start or stop times. To turn the stage back ON, press and hold the Dial/Reset with this screen showing to reactivate the stage.

RPM ACTIVATED SWITCH / 4 STAGE TIMER

The NOC-1 has a built in RPM activated switch. It is compatible with most aftermarket electronic ignition systems including MSD, Mallory, Holley, Crane and Accel and can be used on 4, 6 & 8 cylinder engines. It is not compatible with standard (points) or HEI type ignitions. It may also be used with a magneto ignition if a tach converter is used. The RPM switch can be used to shift by RPM or by time. It can also shift up to 5 speed transmissions at different RPM points. If the RPM switch is not being used, it may be turned into a 4 stage timer for timing another device down track.



Press the RPM/TIMER (R/T) button to access the RPM switch set-up screens. The first thing to do is decide if you want to use the RPM switch output for a 2,3,4, or 5 speed transmission or as a 4 stage timer.

Press the R/T button until one of these set-up screens appear (5 to 7 times depending on which mode you are currently in) then press and hold the Dial/Reset button to change from mode to mode.

**SET RPM OR TIMER
2 SPEED RPM**

2 SPEED RPM: For use with 2 speed transmissions (or 3, 4 & 5 speeds that wish to make all shifts at the same RPM). Every time the shift point is reached, the NOC-1 will output. Once the motor has dropped 200 RPM below the shift point, the switch will reset and shift again once the shift point is reached.

**SET RPM OR TIMER
5 SPEED RPM**

3, 4 & 5 SPEED RPM: For use with 3, 4 & 5 speed transmissions that wish to shift at different RPM points. In this mode the NOC-1 will shift the 1-2 at one RPM and once the motor has dropped 200 RPM, it will shift the 2-3 at a different RPM, then the 3-4, then the 4-5. Every time the transbrake is applied, the sequence is reset and the NOC-1 will go back to the 1-2 shift.

**SET RPM OR TIMER
TIMER**

TIMER: In this mode, the RPM output will become a 4 stage timer. All the timers must be set sequentially larger, meaning timer 2 must be equal to or larger than timer 1, timer 3 must be equal to or larger than timer 2 and timer 4 must be set equal to or larger than timer 3. When timer 1 & 2 or timer 3 & 4 are set the same as one another they will cancel each other out and the output will not change. The four

set-up screens following the summary screen are where you change your timers. Use the scroll arrows or the number buttons to make changes. All four timers start timing at release of the transbrake solenoid so if you had 1.000 in timer 1, 2.000 in timer 2, 3.00 in timer 3 and 3.00 in timer 4 from launch the RPM/TIMER output would not change for 1 second, then change for 1 second (duration = timer 2 minus timer 1) and then not change for the remainder of the pass (timer 3 & 4 cancel each other out). **Please note that timers 1 & 2 are adjustable to the thousandth of a second and timers 3 & 4 are adjustable to the hundredth.**

RPM ACTIVATED SWITCH / 4 STAGE TIMER (CONTINUED)

SET 1-2 SHFT RPM 7200 RPM

When in an RPM mode, the first set-up screens will be your shift RPM's. Press the R/T button repeatedly until the shift point you want to change is displayed (1-2, 2-3, 3-4 or 4-5) then use the scroll arrows or the number buttons to adjust the shift point to the desired RPM.

SETUP DISABL TIM .500 SECONDS

Following the shift point set-up screens you will find the Disable Time. This is the amount of time from the release of the transbrake solenoid that the RPM sensing circuit is disabled. If the car experiences tire spin or converter flash right off the starting line, this setting will prevent accidental up-shifting for the amount of time programmed in. After the disable time expires, the RPM sensing circuit will resume looking at the engine RPM and when the shift point is reached, it will shift the shifter. Use the scroll arrows or the number buttons to adjust your disable time.

SETUP SHFTR TYP AIR

Press and hold the Dial/Reset button in this set-up screen to change your shifter type. When using CO2 or air shifters, or electric "push" style shifters, set the shifter type to "AIR" (power off until shift point then turned on). When using an electric "hold" style shifter, set the shifter type to "ELECTRIC" (power on until shift point then turned off).

SETUP # OF CYLINDERS: 8

Press and hold the Dial/Reset button in this set-up screen to change the number of cylinders from 8 cylinders to 6 cylinders, again for 4 cylinders, and again to return to 8 cylinders.

TACHOMETER 3500 RPM

The NOC-1 has a built in tachometer for testing the incoming tach signal. It can show you if the RPM switch is receiving a good signal. Press the R/T button once to bring up the SET 1-2 SHIFT RPM set-up screen, then push and hold the Dial/Reset button to display the tachometer. As long as you hold the Dial/Reset button the tachometer will stay displayed; release the button to return to the set up menu.

GENERAL INFORMATION AND DEFINITION OF FEATURES

Dial//Reset: Used to change the settings for the type of equipment on your car. For example, the number of engine cylinders, type of shifter, turning stages on and off, etc. To use it for these applications, go to the set-up screen for the feature you wish to change, press and hold the Dial/Reset button until the box changes its set up. If pressed in the ready to run screen, the Dial/Reset button brings up the Dial In set-up screen.

Stage Settings Incorrect: If an "OFF" timer is accidentally set lower than the "ON" timer this message will appear. Change the timers to correct the problem. If the run is made without fixing the problem, the affected stage will not activate.

Leaving Set Up Menus, Five Ways To Leave:

- 1) Do nothing and the unit will return to the run mode automatically after 8 seconds.
- 2) Press the Transbrake button and the unit will instantly return to run mode.
- 3) Clock through the set up menu by repeatedly pushing the setting button until you get back to run mode.
- 4) Go backwards through the set up menu by repeatedly pushing the BACK button.
- 5) Change set up modes (I.e. in the Stage 1 set up, you can press the Stage 2 button and jump directly to the set up menu for stage 2, etc.)

Memory: The microprocessor in the NOC-1 will remember all of your settings, even after turning off the power. There are no internal batteries to die, so the unit will keep your last settings forever.

Battery Chargers: It is important to make sure to have your master disconnect switch off while hooking up your charger between rounds. When the first contact is made between the charger and the battery there may be a voltage spike that could damage electronics. After the charger is hooked up the master switch can be turned back on to run the water pump, fan, etc.

Temperature: If the NOC-1 ever gets over 160 degrees, the display will get dark and unreadable. This does not damage the unit, simply cool it off and the display will return to normal.

Welding: If any welding needs to be done on the vehicle with the NOC-1 installed, make sure to disconnect both the +12 volt and ground leads before starting.

WIRING FOR NITROUS

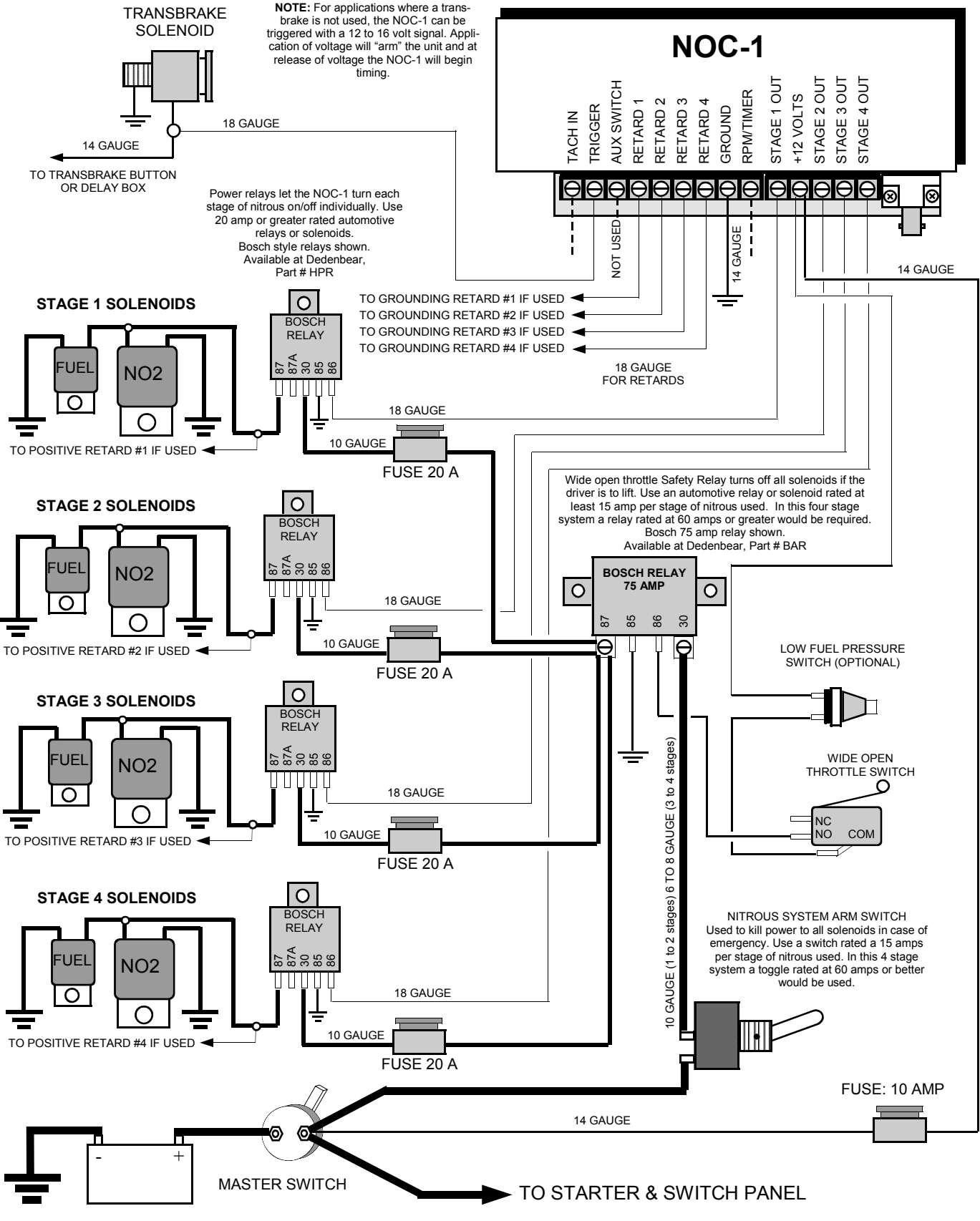

WIRING FOR NITROUS WITH DEDENBEAR MULTIPLE RELAY CENTER

NOTE: For applications where a transbrake is not used, the NOC-1 can be triggered with a 12 to 16 volt signal. Application of voltage will "arm" the unit and at release of voltage the NOC-1 will begin timing.

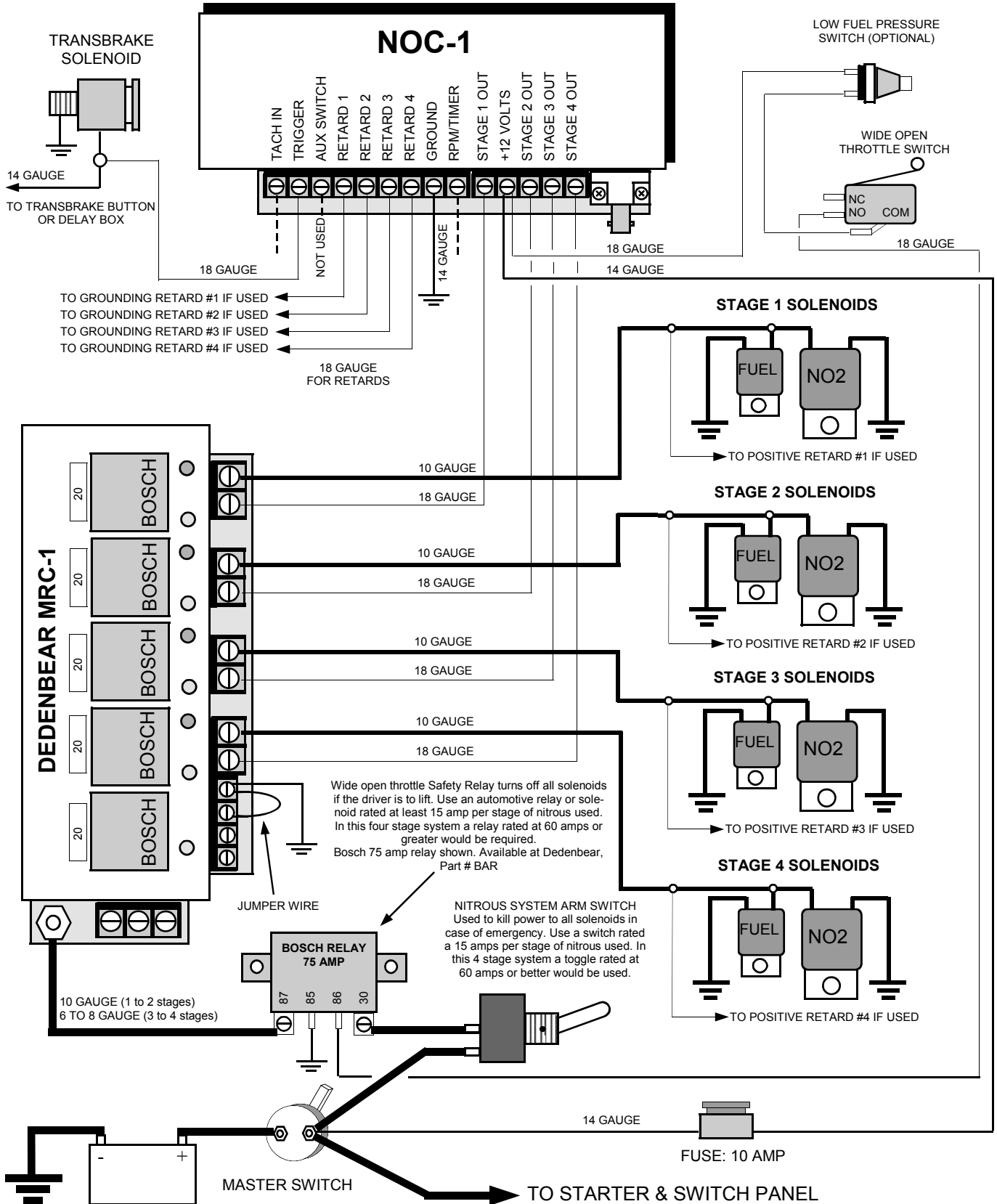

WIRING FOR AIR AND ELECTRIC SHIFTERS

There are 3 different types of automated shifters commonly used in drag racing. They are:

1. **CO2 or "Air" Shifter:** Air shifters require +12 volts to be applied to fire the shifter and make the gear change. **SET SHIFTER TYPE TO "AIR" SHIFTER**
2. **"Hold" Type Electric Shifter:** Hold type shifters such as Dedenbear's models SS-2,4,5&6 require a constant +12 v to hold the plunger back. At the shift point, power is removed and the spring pushes the shifter forward. **SET SHIFTER TYPE TO "ELECTRIC" SHIFTER**
3. **"Push" Type Electric Shifter:** Push style shifters use a large high amperage solenoid that requires the use of a relay or a starter style solenoid to handle the load. These style solenoids use voltage to push the shift lever and make the gear change. **You MUST use a relay or starter solenoid to avoid damage to the NOC-1.** **1. SET SHIFTER TYPE TO "AIR" SHIFTER**

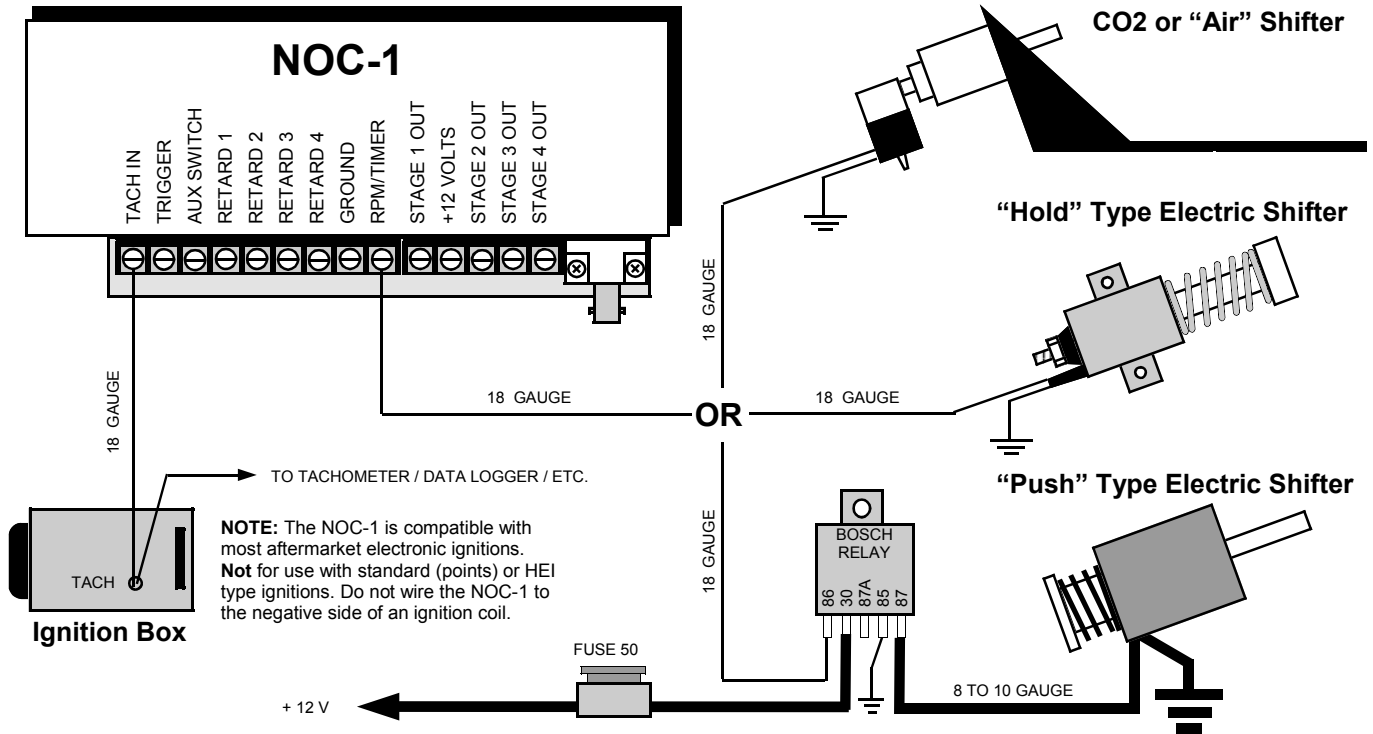

WIRING FOR REMOTE DISPLAY

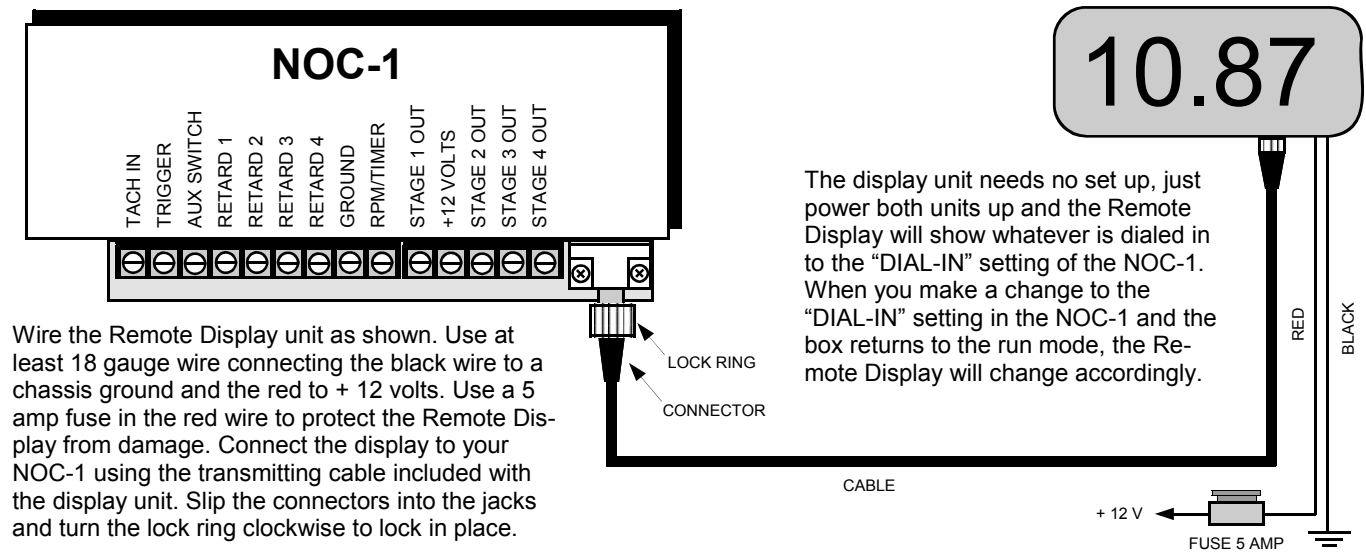

FACTORY SETTINGS AND PARAMETERS

PRO MODE = P/F LIGHT ON FULL MODE = P/F LIGHT OFF		FACTORY	
SETTING	RANGE	PRO	FULL
STAGE 1 START TIME	0.000 to 19.999 sec.	0.000	0.500
STAGE 1 STOP TIME	0.000 to 19.999 sec.	0.000	2.500
STAGE 1 ON OR OFF	ON or OFF	ON	ON
STAGE 2 START TIME	0.000 to 19.999 sec.	0.000	1.000
STAGE 2 STOP TIME	0.000 to 19.999 sec.	0.000	2.500
STAGE 2 ON OR OFF	ON or OFF	ON	ON
STAGE 3 START TIME	0.000 to 19.999 sec.	0.000	1.500
STAGE 3 STOP TIME	0.000 to 19.999 sec.	0.000	2.500
STAGE 3 ON OR OFF	ON or OFF	ON	ON
STAGE 4 START TIME	0.000 to 19.999 sec.	0.000	2.000
STAGE 4 STOP TIME	0.000 to 19.999 sec.	0.000	2.500
STAGE 4 ON OR OFF	ON or OFF	ON	ON
1-2 SHIFT RPM	2000 to 9999 RPM	7500	7500
2-3 SHIFT RPM	2000 to 9999 RPM	7500	7500
3-4 SHIFT RPM	2000 to 9999 RPM	7500	7500
5-4 SHIFT RPM	2000 to 9999 RPM	7500	7500
SHIFT DIASBLE TIME	0.000 to 3.999 sec.	.500	.500
SHIFTER TYPE	Air or Electric	ELEC	ELEC
NUMBER OF CYLINDERS	4, 6, 8 cylinders	8	8
RPM OR TIMER	2,3,4 OR 5 Speed, Timer	2 SPD	2 SPD
OPTIONAL TIMER 1	0.000 to 9.999 sec.	2.000	2.000
OPTIONAL TIMER 2	0.000 to 9.999 sec.	2.500	2.500
OPTIONAL TIMER 3	0.00 to 19.99 sec.	5.00	5.00
OPTIONAL TIMER 4	0.00 to 19.99 sec.	5.00	5.00
OPTIONAL TIMER MODE	OnOffOnOffOn/OffOnOffOnOff	OnOff	OnOff
DIAL-IN	0.00 to 19.99	9.90	9.00

LIMITED 1 YEAR WARRANTY

DEDENBEAR Products, Inc. warrants to the consumer that all DEDENBEAR Products purchased from an Authorized DEDENBEAR Reseller will be free from defects in material and workmanship for a period of twelve (12) months from date of the original purchase. Products that fail within this 12 month warranty period will be repaired or replaced at DEDENBEAR's option, when determined by DEDENBEAR that the product failed due to defects in material or workmanship. This warranty is limited to the repair or replacement of parts in the DEDENBEAR Product and the necessary labor done by DEDENBEAR to effect the repair or replacement of the DEDENBEAR product. In no event shall DEDENBEAR's cost to repair or replace a DEDENBEAR under this warranty exceed the original purchase price of the DEDENBEAR Product. Nor shall DEDENBEAR Products, Inc. be responsible for special, incidental or consequential damages or costs incurred due to the failure of a DEDENBEAR Product. This warranty applies only to the original purchaser of the DEDENBEAR Product and is non-transferable. This warranty also applies only to DEDENBEAR Products purchased from an Authorized DEDENBEAR Reseller. All implied warranties shall be limited in duration to the said 12 month warranty period. Breaking the instrument seal, improper use or installation, accident, water damage, abuse, unauthorized repairs or alterations voids this warranty. DEDENBEAR disclaims any liability for consequential damages due to the breach of any written or implied warranty on all products manufactured by DEDENBEAR Products, Inc.

FOR SERVICE SEND TO: **DEDENBEAR PRODUCTS, INC** 413 W. Elm St. Sycamore, IL 60178 (866) 248-6357

Email: service@autometer.com